

PickCells: A Physically Reconfigurable Cell-composed Touchscreen

Alix Goguey¹, Cameron Steer¹, Andrés Lucero², Laurence Nigay³, Deepak Sahoo¹,
Céline Coutrix⁴, Anne Roudaut⁵, Sriram Subramanian⁶, Yutaka Tokuda⁶, Timothy Neate⁷,
Jennifer Pearson¹, Simon Robinson¹, Matt Jones¹

¹Swansea University, ²Aalto University, ³Université Grenoble-Alpes, ⁴CNRS,

⁵University of Bristol, ⁶University of Sussex, ⁷City University of London

name.surname@{¹swansea.ac.uk, ^{3,4}imag.fr, ⁶sussex.ac.uk, ⁷city.ac.uk }, ²lucero@acm.org, ⁵roudaut@gmail.com

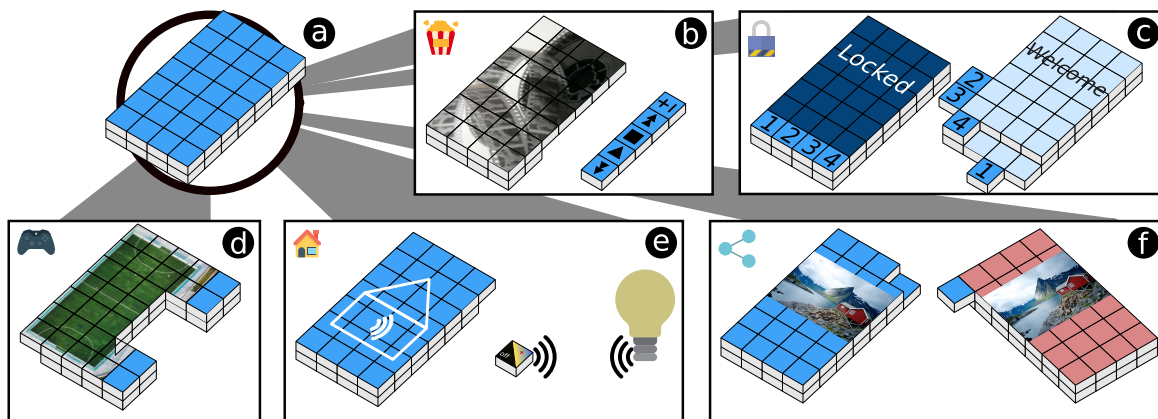

Figure 1: Illustration of the PICKCELLS concept. Using her PICKCELLS device (a) composed of small cubical cells, Eve can: b) snap-off cells to create a remote control while watching her movie; c) reorganise some cells to unlock her device by inputting a physical password; d) shape her device into a controller to comfortably play video games; e) snap-off a cell from her device, set it to control her smart light bulb and leave it in the living room so the whole family can control the bulb; and f) share one of her cell to show her vacation pictures on her friend's device.

ABSTRACT

Touchscreens are the predominant medium for interactions with digital services; however, their current fixed form factor narrows the scope for rich physical interactions by limiting interaction possibilities to a single, planar surface. In this paper we introduce the concept of PICKCELLS, a fully reconfigurable device concept composed of cells, that breaks the mould of rigid screens and explores a modular system

that affords rich sets of tangible interactions and novel across-device relationships. Through a series of co-design activities – involving HCI experts and potential end-users of such systems – we synthesised a design space aimed at inspiring future research, giving researchers and designers a framework in which to explore modular screen interactions. The design space we propose unifies existing works on modular touch surfaces under a general framework and broadens horizons by opening up unexplored spaces providing new interaction possibilities. In this paper, we present the PICKCELLS concept, a design space of modular touch surfaces, and propose a toolkit for quick scenario prototyping.

CCS CONCEPTS

• **Human-centered computing** → Human computer interaction (HCI).

KEYWORDS

Touchscreen, shape changing interface, modular

CHI 2019, May 4–9, 2019, Glasgow, Scotland, UK

© 2019. This is the author's version of the work. It is posted here for your personal use. Not for redistribution. The definitive Version of Record was published in *CHI Conference on Human Factors in Computing Systems Proceedings (CHI 2019)*, May 4–9, 2019, Glasgow, Scotland, UK, <https://doi.org/10.1145/3290605.3300503>.

ACM Reference Format:

Alix Goguey, Cameron Steer, Andrés Lucero, Laurence Nigay, Deepak Sahoo, Céline Coutrix, Anne Roudaut, Sriram Subramanian, Yutaka Tokuda, Timothy Neate, Jennifer Pearson, Simon Robinson and Matt Jones. © 2019. PickCells: A Physically Reconfigurable Cell-composed Touchscreen. In *CHI Conference on Human Factors in Computing Systems Proceedings (CHI 2019)*, May 4–9, 2019, Glasgow, Scotland, UK. ACM, New York, NY, USA, 14 pages.
<https://doi.org/10.1145/3290605.3300503>

1 INTRODUCTION

Pervasive digital devices (such as smartphones, tablets or tabletops) are rigid and remain in their factory-formed shape encapsulating touchscreens that are almost always flat and static surfaces. Interactions are confined to the screen sensing capabilities (e.g. contact points) or potentially 3D positioning (e.g. orientation); and, in all cases, the screen shape cannot be used as a dynamic input. This "sameness" and lack of innovation in all touchscreens has even been noted in the popular press (e.g. [theweek](#)'s article). In contrast, non-fixed form-factor touchscreens could enable a new realm of interactions: for instance, bendable screens (e.g. MagicScroll [16] or PaperTab [52]), and more generally the Organic User Interfaces vision [55], are on the verge of becoming commercially available. While a step forward in increasing the expressiveness of touch interaction, such proposals, though, are still based on screen surfaces that are single entities with set boundaries.

One way to liberate displays from their static and flat form is to enable them to be decomposed into multiple touchscreen surfaces and to design them to be reconfigurable. By moving away from the one device-one screen model to a model of one device-multiple screens, like Lego® bricks composing a model, device shapes and interface affordances would no longer be tied to the single flat surface default. Such modularity, as we will demonstrate, enables countless new ways to interact with touchscreens.

The field of modular devices already demonstrates how devices can be broken apart in useful ways. For example, Seyed *et al.* [48] explored the use of lendable sub-devices from a mobile phone; and, EXHI-bit [36], Sifteo [33] and commercial examples such as the Nintendo® Switch enable degrees of device re-configuration.

In this paper, we integrate previous work on modular devices into a broader framework and contribute PICKCELLS, a fully re-configurable device concept composed of cells. PICKCELLS encompasses key interaction concepts: physical re-configuration (i.e. adaptable form factor); functional re-configuration (i.e. fitting device features to a particular need); and, easy inter-device connectivity (i.e. enabling simple tangible sharing between devices). The PICKCELLS concept is designed to go beyond just accounting for existing works on

modular touch surfaces, though. It opens up the design space and creates new possibilities where the notions of physical configurations and tangible exchanges challenge the common representation of personal devices. Figure 1 illustrates the PICKCELLS concept through five scenarios.

As in the paper that introduced inFORM [14], we focus here on the description and exploration of the design space enabled by our technical concept. Our goal is to unify different uses of modular devices under a single space using a single device, which would help designers and researchers to freely combine ideas derived from multiple existing works, and enable them to explore new ways of using modular devices. After presenting a review of modular devices as well as across-touch-device interactions, we describe the PICKCELLS concept. We then introduce the co-creation methodology we used to enable HCI experts and potential future users to reflect creatively on the concept and its possibilities. We describe the design space derived from use case scenarios designed in the workshop and demonstrate its descriptive and generative power. We also provide an open-source implementation of PICKCELLS giving the community a tool to quickly prototype and evaluate use case scenarios. Along with the video figure, this implementation shows one possible vision of PICKCELLS and how it could be used to implement scenarios from different areas of the design space. Finally, we discuss the wider design implications of such a concept.

2 RELATED WORK

In 1997, Ishii *et al.* shared their vision of Tangible Bits which presented the concept of Tangible User Interfaces (TUIs) [21]. With TUIs, bits of information are embodied in physical objects enabling easier data manipulations. However their fixed forms limit their use to a constrained array of functions as they are not as easily reconfigurable as pixels on a screen. Addressing this limitation, Ishii *et al.* evolved their vision, setting out the Radical Atoms agenda: the use of transformable and reconfigurable material for the future of human-material interaction [20]. With PICKCELLS, we embrace the latter vision by providing reconfigurable tangible pixels. Although we are not using a fully transformable and actuated material as envisioned in the Red Perfect example, we present a concept that explores the use of reconfigurable interfaces at a larger granularity using manually reconfigurable bricks.

Early forms of modular devices have already been explored but these only consider inputs rather than the comprehensive input, output and across device interaction accommodated by our concept. We can for example cite the "bricks" of Fitzmaurice *et al.* [13] that were attached to virtual objects and operated on a tabletop; "Triangles" from Gorbet *et al.* [17] with the manipulation of digital information through the reconfiguration of connectible triangle shaped tangibles; or, ActiveCube [57] which achieve a similar goal with cubes.

In this section, we first focus on related work exploring control reconfigurations. We then present work that focusses on screen reconfigurations and the social interaction and easy cross device sharing this enables. We finally present the Sifteo cubes [33] and their use cases.

Input: control reconfiguration

Modular control could be defined as control that can be physically reconfigured enabling a new way to interact with a device. A good example of such modular control used in commercial devices is the controller of the [Nintendo® Switch](#). Depending on its configuration, the player can, for example, use the console at home or on the go when out and about.

SLAP is a system of translucent widgets that works on a tabletop [58]. Each widget interacts with the system’s content depending on its predefined form factor, the screen behind it updating its current function. Since it is transparent the control can be redefined dynamically. Sparse Tangibles uses smartwatches as active tangibles [2, 3, 12, 29] to visualize and manipulate data on a tabletop. These tangibles can be reconfigured dynamically.

Chan *et al.* [6] developed capacitive bricks that can be recognized on a touchscreen. Each brick is used to control a function of the system. Bricks can also be stacked enabling complex composition of controls. ACTO is a similar project but embeds actuators on the bricks (push button, motors, *etc.*) [56]. Both systems are used on top of a touchscreen such as a tabletop. Similar bricks, but without touchscreens, like the [Modular Robotics Cubelets](#) and Kinematics [37], directly embed functionalities allowing the creation of stand-alone robots. In this example, sensor and actuator bricks communicate to work together as a unit. In the same vein, Zhao *et al.* presented small cubical robots that self-assemble to create tangible proxies for tangible interaction and virtual reality [59]. This work is based on Zooids, a swarm user interface, that also illustrates the concept of molecular interfaces [24].

These previous tangibles do not exchange information between them but rather control data in a bigger system. In DataTiles, though, each tangible is communicating with others in its vicinity [42]. DataTiles are transparent objects on a display with unique tags; when recognized by the display the function tied to the tile is projected on it (video, timer, knob, *etc.*). Tiles act as modular construction units and when combined they work in conjunction to manipulate or display complex data. Tiles are not screens per se (unsurprisingly as this work was published in 2001) but the idea could be adapted with today’s standard touch screen technology.

Bianchi *et al.* [5] extend digital content to a “secondary” display. It uses a transparent sheet of plastic which when positioned, as input, on a tablet touchscreen can be recognized using its capacitive footprint. The system is used to improve the reading experience by using this “screen” as a palette

or a viewport referencing a distant content (previous page, references, *etc.*). As it simulates a screen reconfiguration behavior, it can also be considered as an example of output as well as input reconfigurations.

Output: screen reconfiguration

Screen reconfigurations are primarily used for viewport extension or workspace organization. Works like Tilt displays (a matrix of screens each mounted on a pivot point capable of re-orientation) [1] or Tiltstacks (a matrix of screens capable of re-orientation and slight translations) [53] allow a partial reconfiguration of a screen to dynamically match its content.

In SurfaceConstellation, a modular hardware platform for linking multiple mobile devices [30], users can reorganize their workspace using multiple smart devices as a multi-display environment. The screens are connected using 3D printed stands and a web-based application is used to configure fixed screen setups. Such a system offers workspace reconfiguration using many screens but cannot be changed dynamically. Using the front camera to retrieve the relative position of multiple devices, [25] flexibly expands the workspace across all devices. Similarly, Hamilton *et al.* present a framework allowing users to easily deploy cross device applications taking advantages of unused screens [19]. In all those works, the user requires multiple, and arguably costly, devices; Cubimorph, however, points to a cheaper, dynamic and fully reconfigurable system [45]. It is composed of cubes embedding touchscreens on each face and connected using a hinge-mounted turntable mechanism. The chain cube is able to self-reconfigure and match any 3D shape in order to dynamically adapt the current form factor of the device to match its use (e.g. a game controller). Paddle [40], Projectagami [51] and Morphees [44] also offers a reconfigurable device. The user can fold the device, similar to manipulating origami. Content and application are then adapted to the changed form factor. However the devices in these four projects cannot be torn apart in the way we demonstrate in the PICKCELLS concept.

PaperTab is a tablet composed of multiple flexible touchscreens tracked on the desk using an electro-magnetic tracker [52]. Each display represents an application. They can transfer data across displays or extend a view port. Screens are not modular per se but can be reorganized within the defined tracking space.

EXHI-bit is a mechanical structure for prototyping shape-changing interfaces [36]. It enables the creation of expandable surfaces in both 2D and 3D geometry. Surfaces can also be combined to enable tearable interfaces, which makes it dynamically reconfigurable and partially tearable. Doppio is a reconfigurable and tearable smartwatch with two touchscreens [47]. It encompasses the modular screen aspect of

PICKCELLS: the relative position of the screens enables an expressive input vocabulary for the smartwatch environment.

Cross-device interaction

Expanding an application context across multiple devices not only offers the possibility to create a “bigger” screen, but also enables multi-user collaborations. Even though it does not make use of reconfigurable screens, distributing the overall screen real-estate across multiple devices could be considered as an implementation of a modular screen system. Similar to [25], Dearman *et al.* use images taken by the back cameras of smartphones to create a network of position aware devices [10]. However, instead of expanding the viewport, they enable each device to easily share digital content by the user simply pushing it towards the wanted device. In Better Together, Robinson *et al.* propose a framework to enable cross-device and cross-user applications [43]. It allows multiple users to work on the same application and share data and controls. However, the system does not keep track of the device positions.

With the HuddleLamp, a desktop lamp integrating a camera that tracks devices, Radle *et al.* enables spatially-aware multi-user and multi-device applications as long as the devices are in the camera field of view [39]. Meanwhile, Lucero *et al.* present a system using personal mobile phones for social interaction [26, 27]. Phones are able to sense the relative positions of each other using radio signals. This system supports social interaction through touch and manual gesture across the different devices. JuxtaPinch implements the concept using a pinching technique to connect devices and extend the viewport across several devices [34].

All of these systems cannot be considered as fully modular screens as they require the use of distinct devices. In contrast, Seyed *et al.* propose a smartphone concept integrating two smaller phones for easy sharing and lending [48]. Each sub-phone can be configured to have a restricted access to the phone functionality allowing the user to lend a phone to strangers or friends and controlling their access. Even though the implementation was done with separate devices, the concept envisions the hardware to be fully integrated and thus could be considered a modular screen.

Sifteo cubes

In 2012, Merrill *et al.* presented the Sifteo cubes: a set of cubes integrating a touchscreen and gesture recognition (e.g. shake, tilt or flip)[33] Sifteo was inspired from an earlier project: Siftables a tangible user interface composed of tiles capable of short range sensing and used for visualizing information and physically re-arranging it [32].

A range of application scenarios have been explored in earlier research. In CubeQuery, Sifteo cubes are used on a table top and physically re-arranged to compose database

queries [23]. In [8], Claes *et al.* use them to display and filter data on a tabletop screen. In [38] and [46], cubes are re-arranged to manipulate a game character.

In [15] and [9], the Sifteo cubes have been used to illustrate the concept of object-oriented programming in a course. Rangoni *et al.* use the cubes as tangible widgets (e.g. stamps, pen) to trigger a function on a table top display [41]. In [54], Valdes *et al.* conducted a user-elicitation study to define a vocabulary of gestures to manipulate a data-set displayed on “large” screens. In Active Pathways, Sifteo cubes are used to create and edit biochemical reactions on a tabletop environment [31]. Finally, Sifteo cubes have also been used on a tabletop to simulate interaction between *E. Coli* and an environment [7, 18, 35, 49].

The Sifteos concept is a good example of modular bricks working. However there is a key difference with PICKCELLS: each cube acts as a single independent entity; the cubes never form, and do not begin as, a single device and therefore do not encompass the idea of a tearable, reconfigurable device. Moreover, the previously explored scenarios of the devices have barely explored the inter-cube communication possibilities, and the original Sifteo paper mainly focused on the implementation of the technology.

3 PICKCELLS CONCEPT

All the works presented to this point focus on one particular aspect of modular screen and inter-device interaction. Our aim is to unify them under a single design space and propose a device that can be used to implement existing work and more.

PICKCELLS is a physically reconfigurable device composed of cells. Cells are self-powered entities embedding a touchscreen. Cells can be physically connected to each other. When physically connected, cells form groups that are self aware of their 3D configuration (i.e. how cells are arranged in space). To complete the definition, a group can be composed of one isolated cell or several physically connected cells. At any given time, a PICKCELLS device, which is composed of one or several groups, knows its current configuration. If we use the most common form factor of our modern screen, we could describe each cell as cuboid. In this example, each cuboid cell has a bottom, top, east, west, south and north face. We could for instance connect two cubical cells by their eastern and western faces respectively. In general, PICKCELLS cells could take any form factor derived from a 2D shape that can be repeated in a lattice. For instance a cuboid is derived from a square shape and rectangular-, hexagonal- or triangular-prism are derived from a rectangle, hexagon or triangle shape, respectively. The PICKCELLS concept is agnostic to the shape implemented. For clarity, we use the cuboid cell representation (i.e. square derived) to set a form factor in the rest of the paper.

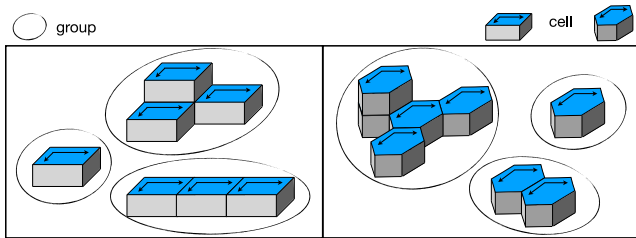

Figure 2: Illustration of the PICKCELLS notions through a cuboid and a hexagonal-prism implementation. Cells are atomic elements (here cubes and hexagonal-prism) whereas groups are isolated or physically connected cells.

To summarise, we distinguish 2 PICKCELLS notions (c.f. Figure 2):

- **Cell**, which represents the atomic level of PICKCELLS. It is an input/output hardware module, that can be physically connected to other cells. In this paper, implementation of cells may also be referred to as cubes.
- **Group**, or group of cells, which represents one isolated cell or several physically connected cells.

4 WORKSHOP DESCRIPTION

Given the range of possible reconfigurations, the PICKCELLS concept offers a lot of possibilities. In order to ease its use and exploration by designers, we aim to formalize and classify them. To ground and expand our understanding of the PICKCELLS design space, we ran a workshop where we gave participants opportunities to create scenarios in a world where PICKCELLS is fully implemented. The structure of the workshop is based on *the dialogue-labs method* from Lucero *et al.* [28] which facilitates participant generation of ideas by stimulating their creative thinking through a sequence of co-design activities.

Participants

In total, 11 participants (27.2 mean age, 10.7 std dev, 2 females, 4 computer scientists, recruited at the local university campus) and 11 HCI researchers were split into 3 sessions. The HCI researchers were from a range of backgrounds: 2 had extensive experience in shape change, 2 in co-design, 5 in hardware, 1 in touch interaction, 1 in design space formalisation. Each had at least 4 years of experience in HCI. Each session lasted around 2 hours and was divided into the following segments.

Segment: Introduction (15 minutes)

The facilitators welcomed the participants and explained the main purpose of the workshop in a *comfortable and relaxed atmosphere* [28] enabling creativity. Participants were presented slides introducing the possible evolutions of multi-touch devices form factors from flexible screens (Samsung

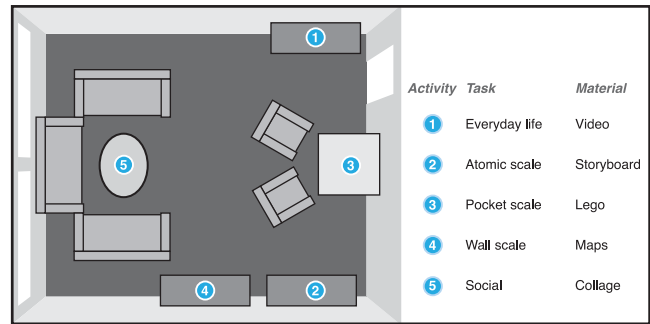

Figure 3: Overview of the room in which the workshop sessions took place. Activities (tasks and materials) and their location in the room are summarized.

Flexible OLED, [The Verge's](#) article) to tearable screens. A few concepts such as Sifteo [33], SurfaceConstellation [30], Cubimorph [45] and [48] were given as examples of thinking beyond single fixed displays. Participants were then presented the PICKCELLS concept and told that the goal was to explore screen reconfigurations and generate ideas that could be feasible in a near future (as opposed to science-fiction scenarios).

Segment: Co-design rounds in pairs (3x15 minutes)

Participants were paired with HCI researchers. Each pair chose and participated in three out of five possible activities (described below). The activities were designed to help participants think of new ideas, scenarios or concepts. Ideas came from the participants and HCI researchers acted as catalysts: they kept pushing the reasoning of the participant by asking questions. HCI researchers also helped by taking a step back and adapting science-fiction ideas into today or near-future realms of possibilities.

The activities fostered creativity by drawing on different thinking and doing skills. Each activity was a combination of a task and materials, and each combination was meant to investigate inputs and outputs at different scales from tiny and individual to large and social interactions. Figure 3 summarizes the activities and their location in the room. The activities were presented and described as follows:

- *Discussing our everyday life*: if you have one/several tablet-size PICKCELLS device(s), what use of it/them would you have? To feed your discussion, you will find a short video compiling various projects¹ similarly exploring a novel idea. This material is meant to be a starting point for a discussion over the concept of PICKCELLS.

¹The projects were: Time Square [Coca-Cola](#) 3D screen advert; Cubimorph [45]; [Mozilla Seabird](#) concept; Tilt displays [1]; SurfaceConstellation [30]; lendable phones [48]; [Samsung Flexible OLED](#); EXHI-bit [36] and inFORM [14].

- *Storyboarding at the atomic scale*: if you have one/several smart-watch-size PICKCELLS device(s), what use of it/them would you have? To support your reflection, we spread out sticky notes on the table along with scissors, pen, tape and blu tack. In front of you, you will find a large white-board with magnets along with flash cards on which human, tables and everyday objects shapes have been (simply) drawn. White-board markers are also available. Use the material to storyboard the use of such devices and how they would be worn.
- *Reshaping at the pocket scale*: if you have one/several phone-size PICKCELLS device(s), what use of it/them would you have? To support your reflexion, you will find a set of Lego® bricks on the table with different sizes and colors. Use and play with the Lego® bricks like you would fiddle around with your phone in order to manipulate a low fidelity prototype of the PICKCELLS concept.
- *Extending at the wall scale*: if you have one/several wall-size PICKCELLS device(s), what use of it/them would you have? To inspire situations where you could interact or use a wall size display, you will find maps on which locations have been pinned such as Heathrow, Piccadilly Circus, local University, Highways and others. Feel free to explore the map to find a location that would inspire your use of the PICKCELLS concept. During this activity round, your pair has to pick and explore at least four different locations and write or draw a scenario.
- *Social interactions in inspiring places*: if you have one/several PICKCELLS device(s) while out and about with others, what use of it/them would you have? To inspire social situations where you could use, interact, share or split devices, you will find a collection of inspiring images. This material is meant to be a starting point for reflecting on the concept of PICKCELLS using the first idea that comes to your mind while looking at the pictures. This activity should enable a discussion between the pair members on how the device could be used if part of one or several pictures².

Segment: Idea sharing & Group co-design (45 minutes)

After a five minutes coffee break, all the participants gathered as a single group. Taking turns, each pair shared an idea generated while going through the activities with the group. At any time, the group was invited to react and build upon the idea being presented. The facilitators took notes on sticky notes and displayed them on a large white board to keep track of the exposed/explored ideas and the activity from

which they were initiated. The pairs took turns until the 45 minutes were elapsed.

In the dialogue-lab method, as in Google Design Sprint [22], the co-design segment is followed by a voting segment. However, we decided not to include this part in our design space reflection. Since our goal was to build a design space covering all the use cases of PICKCELLS, we consider all the participants' ideas.

5 RESULTS: USE CASE SCENARIOS

We present the use case scenarios derived from the ideas presented by the participants during the workshop. We gathered participants' ideas that were describing the same mechanisms, but using different contexts of use, under a single scenario. Finally for clarity of presentation, we grouped them thematically.

Modular customization

Workspace customisation: Alice uses PICKCELLS to customize the layout of her workspace by reorganising the different cells. Each of her cells is tied to functionalities. She uses it to reorganise the keys of her keyboard, change the position of the interactive widgets such as knobs and sliders and reorganise her video editing and sound mixing console.

Minimalism: Bob uses PICKCELLS to select and discard an array of functionalities. To have an uninterrupted reading session at the park, he leaves the social media applications at home. When going for a run, he only takes the step counter.

Modular device: Eve uses PICKCELLS to upgrade or delete certain features of her device. She swaps between different camera cells and battery cells to match her immediate need. The idea is similar to the [Phonebloks](#) vision (implemented by the [Project Ara](#) or the [Fairphone 2](#))) where hardware modules could be bought separately.

Peripheral controls

Physical widgets: Michael uses PICKCELLS to define custom controls to interact on his main group of cells by creating physical switches and slider. He also changes the shape of his device to better interact with his applications. For instance when playing video games, he shapes his device as a video game controller (figure 1-d).

Break-off controls: Emily uses PICKCELLS to create separate controls interacting with her main group of cells. When watching a video, she creates a remote control to pause and resume her video (figure 1-b). She also creates yes/no voting cells that she distributes in her class to conduct live surveys with her students.

Smarthome controls: Matthew uses PICKCELLS to create dedicated cells controlling his smarthome appliances. He set one cell dedicated to switch-on/-off and control the colour of his [Philips Hue](#) light bulb (figure 1-e).

²We used 259 pictures from the galleries of [unsplash.com](#).

Remote sensors: Emma uses PICKCELLS to create remote sensors that transmit data to her main group of cells. For instance she detached her camera cell to spy on her dog while away from home. She also uses cells as GPS trackers to track her suitcases while travelling. When arriving at the airport she gathers flight information by using a cell to harvest information at a dedicated airport stand. Finally when out with friends, she distributes cells as walkie-talkies so they can communicate directly with her when lost in a crowd.

Security

Tangible password: Ethan uses PICKCELLS to lock and unlock his phone by placing cells at a very specific locations. He sets tangible passwords where the physical configuration of a group of cells acts as a combination lock (figure 1-c). He also uses this system to stop his alarm clock and avoid snoozing. In this case he has to match a 3D shape.

Security key: Sarah uses PICKCELLS to grant permission to a digital content or an application such as her email account. She creates tangible security keys embodied by cells. These cells have to be connected to a main group of cells to grant or deny the permission. Some of her security keys are even composed of several cells that have to match a particular shape in the manner of the previously presented *tangible password*.

Data management

Data visualisation: Daniel uses PICKCELLS to dynamically visualise data. He sets a main group of cells as his graph canvas on which data is plotted. He then uses secondary cells to change the axis, split and filter the data on the fly.

Data editing: Hannah uses PICKCELLS to dynamically edit data. She edits her video montage by moving timeline cells tied to sequences around. Similarly, when in a meeting with her architect colleagues, she modifies a city plan on the fly by swapping cells to assess how her modifications affect the traffic and the shadows across the squares, streets and parks.

Trip planner: Andrew and Julie use PICKCELLS to plan their trip in Europe. They use cells to represent Points Of Interests (e.g. cities, museums). Each of them uses their main group of cells to navigate a map and visualise the current information of the trip (e.g. distance, time, cost). They then snap-off cells tied to POIs to modify their trip outline represented by a common group of cells. They can add, remove or reorganise the cells within the common group.

Tracking shared resource: Ashley and her colleagues use PICKCELLS to track their shared resources. She sets a cell to represent a quantity and a set of cells to represent a list of items: in the first case to track how much money they have in their coffee kitty; and in the second, the different tasks of

the sales team. Each of them can be accessed and updated (e.g. recharge or withdraw from the kitty and add or tick-off items) by her co-workers' PICKCELLS device.

Tangible reminders: Nicholas uses PICKCELLS to create physical reminders and bookmarks, like using sticky notes. When doing research on his computer he sets cells to point directly to a web page and PDF section. He then connects these cells in his different PICKCELLS devices to access the content later.

Physicalization of digital content

Repurposable resource: Olivia uses PICKCELLS with her organisation to distribute flyers stored in cells. Her customers can access the digital content on their own PICKCELLS device and re-purpose them afterwards to integrate them as their own cell.

Souvenirs: William uses PICKCELLS as tangible souvenirs. When playing a video game he is regularly awarded trophies and rare game items that he encapsulates in cells to complete his collection. Sometimes, he connects them back to his PICKCELLS device to admire his achievement and gives the souvenirs that he has in multiple instances to his friends. He also stores pictures to expose them or gift them like he did with Polaroid® prints.

Uniqueness: Elizabeth uses PICKCELLS to keep track of the number of instances of a digital data she shares. Whether she stores limited copies of pictures to gift them to friends or grant a one time access to a top-up virtual credit card to her children so they can shop in the mall, she controls access to her data. She started using this system after she bought a digital copy of a movie that she stored in a cell on an online shop. This Digital Rights Management of media content allowed her to lend that movie to friends and retrieve the tangible proxy she had when sharing physical DVDs.

Viewport

Screen perspectives: Tyler and her room-mates from all around the world use PICKCELLS to watch movies. They set different groups of cells on which they display the movie with different subtitle options. Not only does this accommodate their respective level of English but also their different viewpoints. They also set the groups of cells so they can map and watch a 360° video.

Screen sharing: Amy uses PICKCELLS to share her screen with her friends. Since they are planning to rent a flat altogether, she snaps off part of her screen so they can all see the ads at the same time (figure 1-f). They also often share screens to co-create music playlists on [Spotify](#).

As can be seen, some of the scenarios see cells move from one person to another. One of the features of the PICKCELLS concept is to challenge the notion of what in a device is personal with cells flowing freely over time and space. This

will of course require users to “replace” cells that they donate or lend to others and this assumes a future where cells are cheaply and easily available, as today’s Lego® bricks or sticky notes are.

6 DESIGN SPACE

In this section we present a design space for the PICKCELLS concept. It is derived and informed from our analysis of the workshop outcomes (i.e. use case scenarios) and the discussion that was carried out during the idea sharing & group co-design segment.

PICKCELLS allows for a free flow of cells in the 3D. Groups can be reconfigured: they can be split apart and/or connected to other cells or groups of cells. They can also form their own separate groups. All these flows give PICKCELLS a rich array of possibilities. Extending the notion of free flows, cells could not only be re-located within one’s own set of groups but also within someone else’s set of groups. As cells can be unified, no matter the owner, the PICKCELLS concept disrupts the notion of a single personal device.

To ensure a comprehensive mental model for users, we define a design space with two axes capturing two core concepts: the physical configuration of the cells in use and the hierarchy between the cells. The first axis, ARRANGEMENT, describes the physical configuration of cells while in use. Using an analogy with USB sticks, ARRANGEMENT would describe where a USB stick is plugged in during its period of use, independently of whom owns the stick. The second axis, HIERARCHY, describes which cell or group of cells is using the resources of a cell or a group of cells. To continue with the USB stick analogy, HIERARCHY would describe which computer is using the auxiliary storage provided by the stick. This design space is inherently tied to the modular inter-device interaction paradigm, describing both from where and to whom cells communicate. The chosen axes are not the only ones that could have been used, however they provide a new perspective not yet explored by the literature as well as adding a descriptive power to differentiate existing works. We are also careful not to describe it from a function or usage point of view, but rather having a classification based on intrinsic cells characteristics.

In the following, we detail both axes. Both of them are defined from the point of view of the cells composing a group being manipulated to match the configuration required for a given application.

ARRANGEMENT defines a set which describes the relevance of cell positioning such as: the 3D location of a cell and the 3D form factor of a group of cells.

- **FIXED**: the location of each cell within a group or attached to another group conveys a semantic. Changing the location of one or several cells changes the overall semantic. For instance, changing the position of

the cells in the *Tangible password* scenario, dictates whether the password is correct or not.

- **RELATIVE**: the location of each cell within a group or attached to another group conveys a semantic tied to some of its neighbouring cells. Changing the location of one or several cells only changes the overall semantic if the relative positioning semantically tied cells is changed. For instance, in the *Minimalism* scenario, emails are accessible only to the group of cells physically connected to the communication cell.
- **FORMFACTOR**: the group form factor conveys a semantic. Changing the location of one or several cells only changes the overall semantic if the form factor is affected. For instance, in the *Screen perspectives* scenario, the number of different versions of a content available depends directly on the number screen groups available. However, cells within a group can be swapped without affecting the content.
- **NOTRELEVANT**: each cell conveys a semantic independently of its location within a group. Changing the location of one or several cells does not affect the overall semantic. For instance, in the *Workspace customisation* scenario, the location of the cells that composed a keyboard can be completely re-arranged. Physically connected or not, the whole group of cells would still act as a keyboard.

HIERARCHY defines the relationship between cells or group of cells: it introduces a notion of resources dependency.

- **STANDALONE**: is a cell or group of cells functioning independently. For instance, in the *Data Visualisation* scenario, all the cells work together and form an independent group focused on displaying data.
- **Satellite**: is a cell or group of cells functioning dependent on a standalone cell or standalone group of cells. They cannot function without a standalone cell(s). We define two different types of satellite: ORIGINALSATELLITE and BORROWEDSATELLITE.

ORIGINALSATELLITE: a satellite cell(s) which stays synchronised to its initial standalone cell(s) in order to function. Resources can only be used by the initial standalone. For instance, in the *Remote sensor* scenario, a cell used as a GPS tracker refers its position only to its standalone.

BORROWEDSATELLITE: a satellite cell(s) which can be synchronised to any standalone cell(s) in order to function. Resources can be used by any standalone. For instance, in the *Uniqueness* scenario, a cell representing a media content enables the access to the content to any standalone physically connected to it.

The notions of HIERARCHY is inherently tied to the different context of use but also to the notion of ownership. For instance, a cell once labelled BORROWEDSATELLITE in a particular context, could become part of its host STANDALONE if the owners agreed on an ownership transfer, and therefore become a ORIGINALSATELLITE. For instance, a cell representing a unique instance of movie would be labelled BORROWEDSATELLITE if lent but ORIGINALSATELLITE if gifted.

7 DESIGN SPACE VALIDATION

Describing the array of interaction possibilities enabled by PICKCELLS, or more generally the modular inter-device concepts, could be tackled through different angles. Showing the completeness of such a design space is arguably unsolvable. However, we have tackled this by defining two axis characterising unique aspects: capturing the possible physical configurations as well as the semantics for the tangible exchanges afforded by PICKCELLS. Describing the physical configurations (i.e. ARRANGEMENT axis) is an obvious approach. As a matter fact, it is well explored by the related work as shown in the following section. However, the HIERARCHY axis is a novel approach to take, articulating spaces that were not yet explored. This axis echoed concerns from the workshop participants who were wondering how cells would be able to work on different devices. As the approach taken by Delamare *et al.* [11], we aim to validate our design space by showing its descriptive power (i.e. the ability to describe a significant range of existing work [4]) classifying the related work, and its generative power (i.e. the ability to help create new applications [4]) highlighting empty areas of the design space, later populated with our own scenarios.

Descriptive power

To illustrate the descriptive power of our design space, we position the following representative systems of the related work.

Lendable phone [48], DataTiles [42] and Better together [43] are three examples where ARRANGEMENT are NOTRELEVANT. In the lendable phone system, all phones once set, including the auxiliary phones, work independently of their position in 3D space. In a similar way Better Together phones work independently once they start running the application. In DataTiles, each tile carries on its specific task (e.g. weather map specific tile, time controller specific tile) independently of the layout. Then as we look at HIERARCHY DataTiles and Better Together exhibit only STANDALONE behaviour. The group of screens works as a single-goal focused independent group. In Better Together, phones are also STANDALONE themselves since each can be used as a normal phone and break off from the application. In contrast, the lendable phone partly differs along the HIERARCHY axis: the auxiliary phones are ORIGINALSATELLITE that are continuously synchronised and

controlled by the primary phone (e.g. it monitors and can shut down their activities) which a STANDALONE by definition is not.

Other works are based on form factor manipulations and therefore classified as FORMFACTOR. CubiMorph [45] and EXHI-bit [36] are both modular implementations that offer functional [45] or output [36] changes based on the shapes they are morphed into. They both exhibit STANDALONE behaviours as Cubimorph has no removable element and EXHI-bit always works as a single-goal focused device. In addition, EXHI-bit also demonstrates a ORIGINALSATELLITE scenario using a separate controller to alter the visualisation of the screen it was broken from.

Sifteos [33], JuxtaPinch [34], PaperTab [52], Doppio [47] and the *active reading* system in [5] are classified as RELATIVE, each of their component adapting their behaviour in function of their direct vicinity. In Sifteos, cubes can transfer information to the adjacent cubes. In JuxtaPinch, combined phones extend the viewport in function of their position. In PaperTab, screens can transfer information and extend the viewport. In Doppio, the applications and actions depend on the secondary screen position. In [5], the visualisation of the document updates depending on the position of the transparent sheet. However their HIERARCHY differ slightly. In the Sifteo system, all the cubes form a group that acts as its own single purpose entity (i.e. STANDALONE). PaperTab is similarly a confined system and by definition JuxtaPinch requires separate devices which all act as their own STANDALONE. In [5], the transparent sheet acts as a ORIGINALSATELLITE since the sheet only works with and on the tablet, which acts as a STANDALONE by definition. Similarly in Doppio, the secondary screen acts as a ORIGINALSATELLITE since it only works with and around the primary screen acting as a STANDALONE.

Finally, SurfaceConstellations [30] makes use of a FIXED ARRANGEMENT. In this system, once the screen setup has been completed, all the screens are meant to remain at the same position using the 3D printed stands, since they represent a virtual representation of the screen layout. However, it is arguable that the prototype can be broken apart and therefore the screens would have a NOTRELEVANT behaviour. We chose to consider the concept and not the implementation. As for the HIERARCHY axis, SurfaceConstellations is a STANDALONE as all screens form a group which acts as a single-goal focused independent group. As for Better Together, devices are also STANDALONE themselves since each can be used as a normal device and break off from the application.

Even though the [Phonebloks](#) project is not per se a modular screen, it is a good example of a modular system in which the different components acts as BORROWEDSATELLITE on any STANDALONE phone (i.e. the phone skeleton). In most of

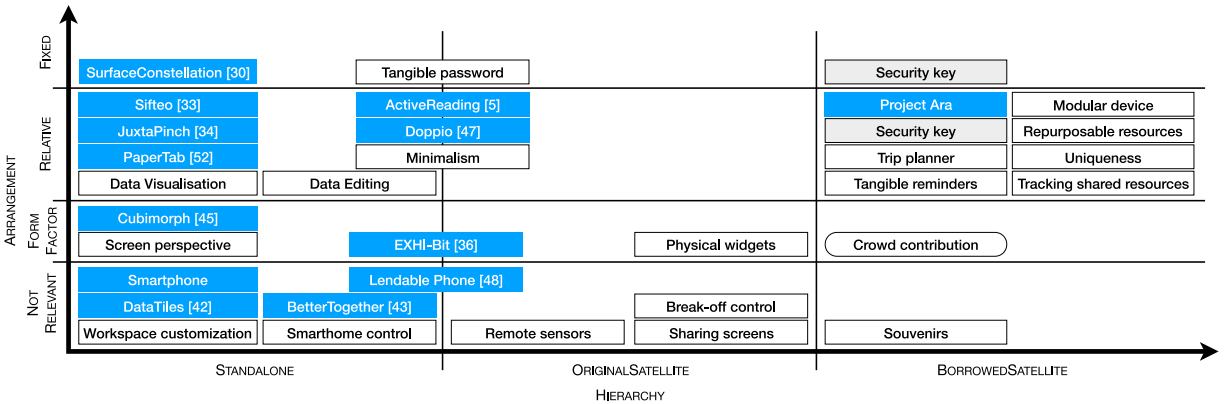

Figure 4: Visual representation of the PICKCELLS design space. The blue rectangular tags represent the existing works used in the *descriptive power* section. The white and grey rectangular tags represent the use case scenarios from the workshop (the grey ones indicate scenarios in multiple areas). The rounded rectangle represent the *Crowd contribution* described in the end of the *generative power* section.

the implementations, the components can be added and attached on different defined slots which makes it a RELATIVE device.

Generative power

In figure 4, we present the ARRANGEMENT and HIERARCHY axis of the design space. From the previous section, we saw that the related work spans across the different region of the ARRANGEMENT axis confirming the descriptive power of our design space. However, they are also grouped on the STANDALONE region of the HIERARCHY axis which confirm the existence of unexplored region in the design space confirming its generative power. For completeness, we populate figure 4 with the use case scenarios derived from our workshop sessions.

After placing the scenarios from the workshop and from the related work, only one area of the design space was left empty: FORMFACTOR & BORROWEDSATELLITE. To populate this area, we came up with different examples adapted from outline ideas mentioned in the workshop and summarize them in the following scenario. All seemed to be part of the realm of art installation.

Crowd contribution: Peter uses PICKCELLS to start a collective creative construction. He places a cell in the middle of a dedicated room in a museum. On the cell can be seen a small portion of an image. He then observes the crowd who donates or lends cells to expand the viewport and display even more of the content. It is the first time he sets this art installation in a museum. He used to do it just for himself and his friends at weddings or house-warming parties.

8 DISCUSSION

With the PICKCELLS concept and the design space, we aimed at unifying the different use of modular devices under a single space using a single device. Our objective is to allow designers and researchers to freely combine ideas derived from multiple existing works, but also to explore new ways of using modular devices. Another goal was to challenge and disrupt the notion of the personal device. Cells can become their self contained device, be loaned and even given to be part of different devices. For designers that want to implement those new behaviours, reflecting on cells access might be necessary. Similar to file system rights on classical operating systems, embedding ownership and life-span properties might come handy. Ownership could be restricted (i.e. cells would only perform the function they were assigned) or unrestricted (i.e. cells would perform the function they were assigned but could also be reprogrammed by any host device), and life-span could be limited (i.e. function would be available for a certain amount of time or a certain number of uses).

Using our design space, we reflected on existing modular systems. This descriptive use of the design space shows that previous prototypes have covered isolated areas of the wider possibilities. This partitioning also shows currently under explored areas which we started to examine with the ideas generated by our workshop participants. Furthermore it highlights the versatility of the PICKCELLS concept, as the whole design space could be covered by a single prototype. However, we do not claim that PICKCELLS is the only concept that could achieve such a wide cover.

It is interesting to note that apart from modular phone projects such as the [Phonebloks](#) vision, the BORROWEDSATELLITE area of the design space, and to some extent the FIXED area, have been barely explored and thus might arguably,

when tackled by designers, open up reflection on compelling innovative concepts. Furthermore, as shown in the *design space validation* section, the only area not explored by the participants was the i.e. BORROWEDSATELLITE and FORMFACTOR. We showed how by thinking about this unpopulated segment of the design space, yielded an atypical use case related to the realm of art installation.

Evaluative power

In [4], Beaudouin-Lafon describes a third power of an interaction model: the evaluative power (i.e. the ability to help assess multiple design alternatives). However, since our implementation of PICKCELLS is the only one exploring this design space, we cannot yet assess the evaluative power of our design space.

All the documentation and sources to replicate our prototype are open-source and can be found at the following Github page: github.com/FITLab-Swansea/PickCells. Each cell is a cube made of a 3D printed case and integrates a £30 smartwatch. The smartwatch embeds a touch sensitive display and runs an android 4.4 OS, which can run our custom application. A lever switch and a magnet are encased in each cube's side. An Arduino board, placed inside the cube, streams the switches change of states to the watch via a Bluetooth module.

Each Android application communicates with a server running on an external computer which purpose is to keep track of the current configuration and touch events. Cubes can be physically connected using the magnets on a 2D plane. When attached or detached, the changes of the switch states update the cubes configuration tracked by the server.

A C++ application running on an external computer, interprets all the information gathered and relayed by the server and determines the different interactions and images to display on the different cubes. Once determined, the application updates the display of each cube via the server.

Since Sifteo is a discontinued product, we needed to bring a new solution and hence provide an open-source implementation that can support a variety of scenarios fitting the presented design space. Compared to Sifteos, small but key differences can be noted: multiple PICKCELLS can become a whole through magnetic snapping; cells work as part of a whole device and not independently; work on Sifteos does not explore the BORROWEDSATELLITE space.

We present this cuboid cell implementation of PICKCELLS (figure 5) to provide an initial tool for rapid prototyping and evaluation of use case scenarios and to encourage other researchers to explore alternative designs.

The design of a fully functioning prototype will necessarily be affected by hardware constraints. However, we caution designers and developers against only considering hardware



Figure 5: Cuboid cell implementation of PICKCELLS.

constrains when choosing cell sizes. Sizes should also be defined with user experience in mind. Choosing cells with a small form factor might offer a lot of interaction possibilities, but as a result the great number of physical manipulations and reconfiguration could confuse the user on their role if the system does not include good affordances (e.g. which cell to break-off to disable social media applications). On the contrary, choosing cells too big might lead to a prototype that will not be as versatile and could even become cumbersome. Another possibility to consider, might be to explore the use of multiple shapes (e.g. using cube-cells alongside line-shape cells or L-shape cells). For instance, one could envision the use of a line-cell as a standalone phone and smaller cube-cells as side cells defining the current use.

To go even further, reflecting on the shape of the cells might also mean exploring how the lattice cells interlock with each other. Instead of reasoning in 2D as we did, one could imagine the use of 3D lattices, for instance.

Limitations and future work

Our goal during the workshop sessions was to bring our participants into a creative mindset hence the *the dialogue-labs method*. Using this method, the resulting ideas are tightly coupled to the activities. Designing diverse enough activities is therefore important as our design space was partly informed by the scenarios created by our participants (i.e. our chosen dimensions reflect their main focus). One could argue that another group could have focused on different topics, leading to a new axis. An interesting future work would be to re-run the workshop with different groups and/or different activities, but also with the presentation of the current design space to further explore the empty areas (or cross areas).

Our hardware implementation of the concept is an exploration prototype which we use to illustrate some possible scenarios mapped to the PICKCELLS design space. It should not be seen as a final, complete implementation but rather as an initial example which future iterations can draw inspiration from. For instance, our prototype lacks z-axis connections and relies on external hardware to track its configuration.

It is, though, simple enough for researchers to reproduce it and build upon it.

Another limitation might include the hardware size, cost and efficiency. Designing a prototype that can be small, cheap and battery efficient might not yet be feasible with current technologies. Although smartwatches as used in our prototype seem to be good candidate, they remain expensive when multiplying the number of cells. As a comparison, we also tailor-made 6 cube-cells at a total cost of around £300 including all the components. Research, such as [50] which helps reduce the cost of screens, is therefore still needed to envision the concept of PICKCELLS at large scale. Another solution, might also be to iterate on the hardware architecture of the concept. For example, one could envision cells with different computational power differentiating standalone and satellite cells. Some context of use might include the use of sensors, such as cameras, compasses or fingerprint readers. Specializing cells would for instance help reduce the battery consumption of individual cells.

9 CONCLUSION

In this paper we proposed PICKCELLS, a fully re-configurable device concept composed of cells. It explores physical re-configuration, functional re-configuration and easy inter-device connectivity to break the mould of rigid screens, challenging and disrupting the notion of personal device. Along with the concept we provided an open-source implementation for quick scenario prototyping. We formalized the use of PICKCELLS in a design space with 2 axis describing the physical configuration of the cells in use and the hierarchy between the cells. We synthesised this design space from scenarios crafted during a series of co-design activities – involving HCI experts and potential end-users of such systems – following the *dialogue-labs* method. We validated the proposed design space by demonstrating its descriptive and generative powers. Both PICKCELLS and its design space are meant to unify uses of modular devices under a single space using a single device, to freely combine ideas derived from multiple existing works, and explore new scenarios. While the implementation of this new concept will need time to mature, it outlines the shape of a new design in an effort to revitalize innovation on touchscreens.

10 ACKNOWLEDGMENTS

This work was supported by the Engineering and Physical Sciences Research Council award number EP/N013948/1 and EPSRC EP/P004342/1. We also thank Ben Jones for his help on the hardware.

REFERENCES

- [1] Jason Alexander, Andrés Lucero, and Sriram Subramanian. 2012. Tilt Displays: Designing Display Surfaces with Multi-axis Tilting and Actuation. In *Proceedings of the 14th International Conference on Human-computer Interaction with Mobile Devices and Services (MobileHCI '12)*. ACM, New York, NY, USA, 161–170. <https://doi.org/10.1145/2371574.2371600>
- [2] Ahmed Sabbir Arif, Brien East, Sean DeLong, Roozbeh Manshaei, Apurva Gupta, Manasvi Lalwani, and Ali Mazalek. 2017. Extending the Design Space of Tangible Objects via Low-Resolution Edge Displays. In *Proceedings of the Eleventh International Conference on Tangible, Embedded, and Embodied Interaction (TEI '17)*. ACM, New York, NY, USA, 481–488. <https://doi.org/10.1145/3024969.3025078>
- [3] Ahmed Sabbir Arif, Roozbeh Manshaei, Sean DeLong, Brien East, Matthew Kyan, and Ali Mazalek. 2016. Sparse Tangibles: Collaborative Exploration of Gene Networks Using Active Tangibles and Interactive Tabletops. In *Proceedings of the TEI '16: Tenth International Conference on Tangible, Embedded, and Embodied Interaction (TEI '16)*. ACM, New York, NY, USA, 287–295. <https://doi.org/10.1145/2839462.2839500>
- [4] Michel Beaudouin-Lafon. 2004. Designing Interaction, Not Interfaces. In *Proceedings of the Working Conference on Advanced Visual Interfaces (AVI '04)*. ACM, New York, NY, USA, 15–22. <https://doi.org/10.1145/989863.989865>
- [5] Andrea Bianchi, So-Ryang Ban, and Ian Oakley. 2015. Designing a Physical Aid to Support Active Reading on Tablets. In *Proceedings of the 33rd Annual ACM Conference on Human Factors in Computing Systems (CHI '15)*. ACM, New York, NY, USA, 699–708. <https://doi.org/10.1145/2702123.2702303>
- [6] Liwei Chan, Stefanie Müller, Anne Roudaut, and Patrick Baudisch. 2012. CapStones and ZebraWidgets: Sensing Stacks of Building Blocks, Dials and Sliders on Capacitive Touch Screens. In *Proceedings of the SIGCHI Conference on Human Factors in Computing Systems (CHI '12)*. ACM, New York, NY, USA, 2189–2192. <https://doi.org/10.1145/2207676.2208371>
- [7] Kimberly Chang, Wendy Xu, Nicole Francisco, Consuelo Valdes, Robert Kincaid, and Orit Shaer. 2012. SynFlo: An Interactive Installation Introducing Synthetic Biology Concepts. In *Proceedings of the 2012 ACM International Conference on Interactive Tabletops and Surfaces (ITS '12)*. ACM, New York, NY, USA, 303–306. <https://doi.org/10.1145/2396636.2396685>
- [8] Sandy Claes, Jorgos Coenen, Karin Slegers, and Andrew Vande Moere. 2015. Design Implications of Casual Health Visualization on Tangible Displays. In *Proceedings of the 33rd Annual ACM Conference Extended Abstracts on Human Factors in Computing Systems (CHI EA '15)*. ACM, New York, NY, USA, 1839–1844. <https://doi.org/10.1145/2702613.2732830>
- [9] José María Rodríguez Corral, Antón Civit Balcells, Arturo Morgado Estévez, Gabriel Jiménez Moreno, and María José Ferreira Ramos. 2014. A game-based approach to the teaching of object-oriented programming languages. *Computers & Education* 73 (2014), 83 – 92. <https://doi.org/10.1016/j.compedu.2013.12.013>
- [10] David Dearman, Richard Guy, and Khai Truong. 2012. Determining the Orientation of Proximate Mobile Devices Using Their Back Facing Camera. In *Proceedings of the SIGCHI Conference on Human Factors in Computing Systems (CHI '12)*. ACM, New York, NY, USA, 2231–2234. <https://doi.org/10.1145/2207676.2208377>
- [11] William Delamare, Céline Coutrix, and Laurence Nigay. 2015. Designing Guiding Systems for Gesture-based Interaction. In *Proceedings of the 7th ACM SIGCHI Symposium on Engineering Interactive Computing Systems (EICS '15)*. ACM, New York, NY, USA, 44–53. <https://doi.org/10.1145/2774225.2774847>
- [12] Brien East, Sean DeLong, Roozbeh Manshaei, Ahmed Arif, and Ali Mazalek. 2016. Actibles: Open Source Active Tangibles. In *Proceedings of the 2016 ACM International Conference on Interactive Surfaces and*

- Spaces (ISS '16)*. ACM, New York, NY, USA, 469–472. <https://doi.org/10.1145/2992154.2996874>
- [13] George W Fitzmaurice, Hiroshi Ishii, and William AS Buxton. 1995. Bricks: laying the foundations for graspable user interfaces. In *Proceedings of the SIGCHI conference on Human factors in computing systems*. ACM Press/Addison-Wesley Publishing Co., 442–449.
- [14] Sean Follmer, Daniel Leithinger, Alex Olwal, Akimitsu Hogge, and Hiroshi Ishii. 2013. inFORM: Dynamic Physical Affordances and Constraints Through Shape and Object Actuation. In *Proceedings of the 26th Annual ACM Symposium on User Interface Software and Technology (UIST '13)*. ACM, New York, NY, USA, 417–426. <https://doi.org/10.1145/2501988.2502032>
- [15] Mark Goadrich. 2014. Incorporating Tangible Computing Devices into CS1. *J. Comput. Sci. Coll.* 29, 5 (May 2014), 23–31. <http://dl.acm.org/citation.cfm?id=2600623.2600627>
- [16] Antonio Gomes, Lahiru Lakmal Priyadarshana, Aaron Visser, Juan Pablo Carrascal, and Roel Vertegaal. 2018. MagicScroll: A Rollable Display Device with Flexible Screen Real Estate and Gestural Input. In *Proceedings of the 20th International Conference on Human-Computer Interaction with Mobile Devices and Services (MobileHCI '18)*. ACM, New York, NY, USA, 10. <http://www.hml.queensu.ca/s/MagicScrollWand-MobileHCI2018-Final-CRC-v60-8kr3.pdf>
- [17] Matthew G. Gorbet, Maggie Orth, and Hiroshi Ishii. 1998. Triangles: Tangible Interface for Manipulation and Exploration of Digital Information Topography. In *Proceedings of the SIGCHI Conference on Human Factors in Computing Systems (CHI '98)*. ACM Press/Addison-Wesley Publishing Co., New York, NY, USA, 49–56. <https://doi.org/10.1145/274644.274652>
- [18] Casey Grote, Evan Segreto, Johanna Okerlund, Robert Kincaid, and Orit Shaer. 2015. Eugenie: Multi-Touch and Tangible Interaction for Bio-Design. In *Proceedings of the Ninth International Conference on Tangible, Embedded, and Embodied Interaction (TEI '15)*. ACM, New York, NY, USA, 217–224. <https://doi.org/10.1145/2677199.2680605>
- [19] Peter Hamilton and Daniel J. Wigdor. 2014. Conductor: Enabling and Understanding Cross-device Interaction. In *Proceedings of the SIGCHI Conference on Human Factors in Computing Systems (CHI '14)*. ACM, New York, NY, USA, 2773–2782. <https://doi.org/10.1145/2556288.2557170>
- [20] Hiroshi Ishii, Dávid Lakatos, Leonardo Bonanni, and Jean-Baptiste Labrune. 2012. Radical Atoms: Beyond Tangible Bits, Toward Transformable Materials. *interactions* 19, 1 (Jan. 2012), 38–51. <https://doi.org/10.1145/2065327.2065337>
- [21] Hiroshi Ishii and Brygg Ullmer. 1997. Tangible Bits: Towards Seamless Interfaces Between People, Bits and Atoms. In *Proceedings of the ACM SIGCHI Conference on Human Factors in Computing Systems (CHI '97)*. ACM, New York, NY, USA, 234–241. <https://doi.org/10.1145/258549.258715>
- [22] J. Knapp, J. Zeratsky, and B. Kowitz. 2016. *Sprint: How to Solve Big Problems and Test New Ideas in Just Five Days*. Simon & Schuster. <https://books.google.fi/books?id=rV0JCgAAQBAJ>
- [23] Ricardo Langner, Anton Augsburg, and Raimund Dachsel. 2014. CubeQuery: Tangible Interface for Creating and Manipulating Database Queries. In *Proceedings of the Ninth ACM International Conference on Interactive Tabletops and Surfaces (ITS '14)*. ACM, New York, NY, USA, 423–426. <https://doi.org/10.1145/2669485.2669526>
- [24] Mathieu Le Goc, Lawrence H. Kim, Ali Parsaei, Jean-Daniel Fekete, Pierre Dragicevic, and Sean Follmer. 2016. Zooids: Building Blocks for Swarm User Interfaces. In *Proceedings of the 29th Annual Symposium on User Interface Software and Technology (UIST '16)*. ACM, New York, NY, USA, 97–109. <https://doi.org/10.1145/2984511.2984547>
- [25] Ming Li and Leif Kobbelt. 2012. Dynamic Tiling Display: Building an Interactive Display Surface Using Multiple Mobile Devices. In *Proceedings of the 11th International Conference on Mobile and Ubiquitous Multimedia (MUM '12)*. ACM, New York, NY, USA, Article 24, 4 pages. <https://doi.org/10.1145/2406367.2406397>
- [26] Andrés Lucero, Jussi Holopainen, and Tero Jokela. 2011. Pass-them-around: Collaborative Use of Mobile Phones for Photo Sharing. In *Proceedings of the SIGCHI Conference on Human Factors in Computing Systems (CHI '11)*. ACM, New York, NY, USA, 1787–1796. <https://doi.org/10.1145/1978942.1979201>
- [27] Andrés Lucero, Jaakko Keränen, and Tero Jokela. 2010. Social and Spatial Interactions: Shared Co-located Mobile Phone Use. In *CHI '10 Extended Abstracts on Human Factors in Computing Systems (CHI EA '10)*. ACM, New York, NY, USA, 3223–3228. <https://doi.org/10.1145/1753846.1753962>
- [28] Andrés Lucero, Kirsikka Vaajakallio, and Peter Dalsgaard. 2012. The dialogue-labs method: process, space and materials as structuring elements to spark dialogue in co-design events. *CoDesign* 8, 1 (2012), 1–23. <https://doi.org/10.1080/15710882.2011.609888> arXiv:<https://doi.org/10.1080/15710882.2011.609888>
- [29] Roozbeh Manshaei, Nauman Baig, Sean DeLong, Shahin Khayyer, Brien East, and Ali Mazalek. 2016. Exploring Genetic Mutations on Mitochondrial DNA Cancer Data with Interactive Tabletop and Active Tangibles. In *Proceedings of the 2016 ACM International Conference on Interactive Surfaces and Spaces (ISS '16)*. ACM, New York, NY, USA, 461–464. <https://doi.org/10.1145/2992154.2996873>
- [30] Nicolai Marquardt, Frederik Brudy, Can Liu, Ben Bengler, and Christian Holz. 2018. SurfaceConstellations: A Modular Hardware Platform for Ad-Hoc Reconfigurable Cross-Device Workspaces. In *Proceedings of the 2018 CHI Conference on Human Factors in Computing Systems (CHI '18)*. ACM, New York, NY, USA, Article 354, 14 pages. <https://doi.org/10.1145/3173574.3173928>
- [31] Meghna Mehta, Ahmed Sabbir Arif, Apurva Gupta, Sean DeLong, Roozbeh Manshaei, Graceline Williams, Manasvi Lalwani, Sanjay Chandrasekharan, and Ali Mazalek. 2016. Active Pathways: Using Active Tangibles and Interactive Tabletops for Collaborative Modeling in Systems Biology. In *Proceedings of the 2016 ACM International Conference on Interactive Surfaces and Spaces (ISS '16)*. ACM, New York, NY, USA, 129–138. <https://doi.org/10.1145/2992154.2992176>
- [32] David Merrill, Jeevan Kalanithi, and Pattie Maes. 2007. Siftables: Towards Sensor Network User Interfaces. In *Proceedings of the 1st International Conference on Tangible and Embedded Interaction (TEI '07)*. ACM, New York, NY, USA, 75–78. <https://doi.org/10.1145/1226969.1226984>
- [33] David Merrill, Emily Sun, and Jeevan Kalanithi. 2012. Sifteo Cubes. In *CHI '12 Extended Abstracts on Human Factors in Computing Systems (CHI EA '12)*. ACM, New York, NY, USA, 1015–1018. <https://doi.org/10.1145/2212776.2212374>
- [34] Heidi Selmer Nielsen, Marius Pallisgaard Olsen, Mikael B. Skov, and Jesper Kjeldskov. 2014. JuxtaPinch: An Application for Collocated Multi-device Photo Sharing. In *Proceedings of the 16th International Conference on Human-computer Interaction with Mobile Devices and Services (MobileHCI '14)*. ACM, New York, NY, USA, 417–420. <https://doi.org/10.1145/2628363.2633569>
- [35] Johanna Okerlund, Evan Segreto, Casey Grote, Lauren Westendorf, Anja Scholze, Romie Littrell, and Orit Shaer. 2016. SynFlo: A Tangible Museum Exhibit for Exploring Bio-Design. In *Proceedings of the TEI '16: Tenth International Conference on Tangible, Embedded, and Embodied Interaction (TEI '16)*. ACM, New York, NY, USA, 141–149. <https://doi.org/10.1145/2839462.2839488>
- [36] Michaël Ortega, Jérôme Maisonnasse, and Laurence Nigay. 2017. EXHi-bit: A Mechanical Structure for Prototyping EXpandable Hand-held Interfaces. In *Proceedings of the 19th International Conference on Human-Computer Interaction with Mobile Devices and Services (MobileHCI '17)*. ACM, New York, NY, USA, Article 4, 11 pages. <https://doi.org/10.1145/3173574.3173928>

//doi.org/10.1145/3098279.3098533

- [37] Leonhard Oschuetz, Daniel Wessolek, and Wolfgang Sattler. 2010. Constructing with Movement: Kinematics. In *Proceedings of the Fourth International Conference on Tangible, Embedded, and Embodied Interaction (TEI '10)*. ACM, New York, NY, USA, 257–260. <https://doi.org/10.1145/1709886.1709938>
- [38] Clément Pillias, Raphaël Robert-Bouchard, and Guillaume Levieux. 2014. Designing Tangible Video Games: Lessons Learned from the Sifteo Cubes. In *Proceedings of the 32Nd Annual ACM Conference on Human Factors in Computing Systems (CHI '14)*. ACM, New York, NY, USA, 3163–3166. <https://doi.org/10.1145/2556288.2556991>
- [39] Roman Rädle, Hans-Christian Jetter, Nicolai Marquardt, Harald Reiterer, and Yvonne Rogers. 2014. HuddleLamp: Spatially-Aware Mobile Displays for Ad-hoc Around-the-Table Collaboration. In *Proceedings of the Ninth ACM International Conference on Interactive Tabletops and Surfaces (ITS '14)*. ACM, New York, NY, USA, 45–54. <https://doi.org/10.1145/2669485.2669500>
- [40] Raf Ramakers, Johannes Schöning, and Kris Luyten. 2014. Paddle: Highly Deformable Mobile Devices with Physical Controls. In *Proceedings of the SIGCHI Conference on Human Factors in Computing Systems (CHI '14)*. ACM, New York, NY, USA, 2569–2578. <https://doi.org/10.1145/2556288.2557340>
- [41] Yves Rangoni, Valérie Maquil, Eric Tobias, and Eric Ras. 2014. Implementing Widgets Using Sifteo Cubes for Visual Modelling on Tangible User Interfaces. In *Proceedings of the 2014 ACM SIGCHI Symposium on Engineering Interactive Computing Systems (EICS '14)*. ACM, New York, NY, USA, 205–210. <https://doi.org/10.1145/2607023.2610271>
- [42] Jun Rekimoto, Brygg Ullmer, and Haruo Oba. 2001. DataTiles: A Modular Platform for Mixed Physical and Graphical Interactions. In *Proceedings of the SIGCHI Conference on Human Factors in Computing Systems (CHI '01)*. ACM, New York, NY, USA, 269–276. <https://doi.org/10.1145/365024.365115>
- [43] Simon Robinson, Jennifer Pearson, Matt Jones, Anirudha Joshi, and Shashank Ahire. 2017. Better Together: Disaggregating Mobile Services for Emergent Users. In *Proceedings of the 19th International Conference on Human-Computer Interaction with Mobile Devices and Services (MobileHCI '17)*. ACM, New York, NY, USA, Article 44, 13 pages. <https://doi.org/10.1145/3098279.3098534>
- [44] Anne Roudaut, Abhijit Karnik, Markus Löchtfeld, and Sriram Subramanian. 2013. Morpheus: Toward High "Shape Resolution" in Self-actuated Flexible Mobile Devices. In *Proceedings of the SIGCHI Conference on Human Factors in Computing Systems (CHI '13)*. ACM, New York, NY, USA, 593–602. <https://doi.org/10.1145/2470654.2470738>
- [45] A. Roudaut, D. Krusteva, M. McCoy, A. Karnik, K. Ramani, and S. Subramanian. 2016. Cubimorph: Designing modular interactive devices. In *2016 IEEE International Conference on Robotics and Automation (ICRA)*. 3339–3345. <https://doi.org/10.1109/ICRA.2016.7487508>
- [46] Pejman Sajjadi, Edgar Omar Cebolledo Gutierrez, Sandra Trullemans, and Olga De Troyer. 2014. Maze Commander: A Collaborative Asynchronous Game Using the Oculus Rift & the Sifteo Cubes. In *Proceedings of the First ACM SIGCHI Annual Symposium on Computer-human Interaction in Play (CHI PLAY '14)*. ACM, New York, NY, USA, 227–236. <https://doi.org/10.1145/2658537.2658690>
- [47] Teddy Seyed, Xing-Dong Yang, and Daniel Vogel. 2016. Doppio: A Reconfigurable Dual-Face Smartwatch for Tangible Interaction. In *Proceedings of the 2016 CHI Conference on Human Factors in Computing Systems (CHI '16)*. ACM, New York, NY, USA, 4675–4686. <https://doi.org/10.1145/2858036.2858256>
- [48] Teddy Seyed, Xing-Dong Yang, and Daniel Vogel. 2017. A Modular Smartphone for Lending. In *Proceedings of the 30th Annual ACM Symposium on User Interface Software and Technology (UIST '17)*. ACM, New York, NY, USA, 205–215. <https://doi.org/10.1145/3126594.3126633>
- [49] Orit Shaer, Consuelo Valdes, Sirui Liu, Kara Lu, Kimberly Chang, Wendy Xu, Traci L. Haddock, Swapnil Bhatia, Douglas Densmore, and Robert Kincaid. 2014. Designing Reality-based Interfaces for Experiential Bio-design. *Personal Ubiquitous Comput.* 18, 6 (Aug. 2014), 1515–1532. <https://doi.org/10.1007/s00779-013-0752-1>
- [50] D. Sweeney, N. Chen, S. Hodges, and T. Grosse-Puppenthal. 2016. Displays as a Material: A Route to Making Displays More Pervasive. *IEEE Pervasive Computing* 15, 3 (July 2016), 77–82. <https://doi.org/10.1109/MPRV.2016.56>
- [51] Dominique Tan, Maciej Kumorek, Andres A. Garcia, Adam Mooney, and Derek Bekoe. 2015. Projectagami: A Foldable Mobile Device with Shape Interactive Applications. In *Proceedings of the 33rd Annual ACM Conference Extended Abstracts on Human Factors in Computing Systems (CHI EA '15)*. ACM, New York, NY, USA, 1555–1560. <https://doi.org/10.1145/2702613.2732801>
- [52] Aneesh P. Tarun, Peng Wang, Audrey Girouard, Paul Strohmeier, Derek Reilly, and Roel Vertegaal. 2013. PaperTab: An Electronic Paper Computer with Multiple Large Flexible Electrophoretic Displays. In *CHI '13 Extended Abstracts on Human Factors in Computing Systems (CHI EA '13)*. ACM, New York, NY, USA, 3131–3134. <https://doi.org/10.1145/2468356.2479628>
- [53] John Tiab, Sebastian Boring, Paul Strohmeier, Anders Markussen, Jason Alexander, and Kasper Hornbæk. 2018. Tiltstacks: Composing Shape-changing Interfaces Using Tilting and Stacking of Modules. In *Proceedings of the 2018 International Conference on Advanced Visual Interfaces (AVI '18)*. ACM, New York, NY, USA, Article 44, 5 pages. <https://doi.org/10.1145/3206505.3206530>
- [54] Consuelo Valdes, Diana Eastman, Casey Grote, Shantanu Thatte, Orit Shaer, Ali Mazalek, Brygg Ullmer, and Miriam K. Konkel. 2014. Exploring the Design Space of Gestural Interaction with Active Tokens Through User-defined Gestures. In *Proceedings of the 32Nd Annual ACM Conference on Human Factors in Computing Systems (CHI '14)*. ACM, New York, NY, USA, 4107–4116. <https://doi.org/10.1145/2556288.2557373>
- [55] Roel Vertegaal and Ivan Poupyrev. 2008. Introduction. *Commun. ACM* 51, 6 (June 2008), 26–30. <https://doi.org/10.1145/1349026.1349033>
- [56] Emanuel Vonach, Georg Gerstweiler, and Hannes Kaufmann. 2014. ACTO: A Modular Actuated Tangible User Interface Object. In *Proceedings of the Ninth ACM International Conference on Interactive Tabletops and Surfaces (ITS '14)*. ACM, New York, NY, USA, 259–268. <https://doi.org/10.1145/2669485.2669522>
- [57] Ryoichi Watanabe, Yuichi Itoh, Masatsugu Asai, Yoshifumi Kitamura, Yoshifumi Kitamura, Fumio Kishino, and Hideo Kikuchi. 2004. The Soul of ActiveCube: Implementing a Flexible, Multimodal, Three-dimensional Spatial Tangible Interface. *Comput. Entertain.* 2, 4 (Oct. 2004), 15–15. <https://doi.org/10.1145/1037851.1037874>
- [58] Malte Weiss, Julie Wagner, Yvonne Jansen, Roger Jennings, Ramsin Khoshabeh, James D. Hollan, and Jan Borchers. 2009. SLAP Widgets: Bridging the Gap Between Virtual and Physical Controls on Tabletops. In *Proceedings of the SIGCHI Conference on Human Factors in Computing Systems (CHI '09)*. ACM, New York, NY, USA, 481–490. <https://doi.org/10.1145/1518701.1518779>
- [59] Yiwei Zhao, Lawrence H. Kim, Ye Wang, Mathieu Le Goc, and Sean Follmer. 2017. Robotic Assembly of Haptic Proxy Objects for Tangible Interaction and Virtual Reality. In *Proceedings of the 2017 ACM International Conference on Interactive Surfaces and Spaces (ISS '17)*. ACM, New York, NY, USA, 82–91. <https://doi.org/10.1145/3132272.3134143>